

# Black Cat Bucket Protection

5604-59 Street Edmonton, AB T6B 3C3 Canada Toll Free: 1.800.661.6666 Ph: 780.465.6666 Fax: 780.465.9595

[www.BlackCatBlades.com](http://www.BlackCatBlades.com) [sales@blackcatblades.com](mailto:sales@blackcatblades.com)



All Black Cat Bucket Protection Wear Parts are manufactured to our exacting specifications using specially formulated HighSpec Alloy steels to ensure excellent wear characteristics. Parts are computer designed and field tested to offer the customer optimum protection in critical wear areas while assuring ease of installation wherever possible. Protecting the base edge, sidewalls, and underside of the bucket with easily changed wear parts prolongs the life of the bucket and avoids costly repairs and rebuilds. Black Cat Quality Wear Parts, the last line of defence for your buckets.

Caterpillar® and other identities and/or trademarks referred to in this publication are the registered marks of the entities noted herein. The use of any trademarks of others than Black Cat Blades Ltd. are solely and exclusively for identification, informational, comparative, and descriptive purposes. Black Cat Blades Ltd. is not affiliated with any owner of such registered marks and does not make, use, or sell any products manufactured by any such entity identified in this publication.

**Black Cat Heat Treated Products are warranted against breakage during the usable life of the part.**

**305.0411**

### Weld On Heel Shroud

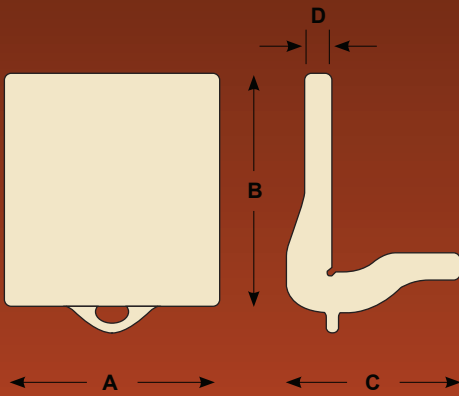

### Corner Guard Protector

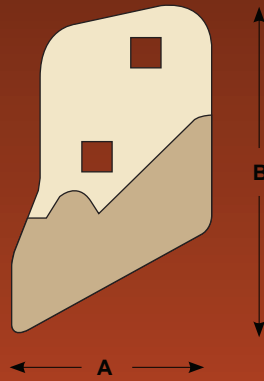

### Weld On Lip Shrouds

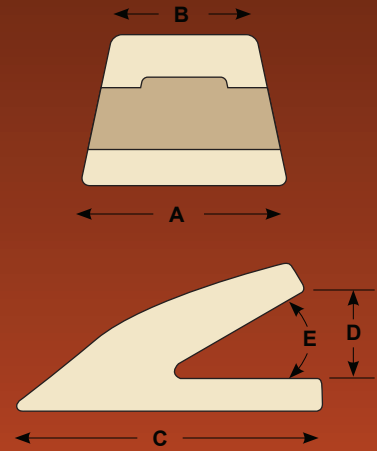

### Weld On Heel Shrouds

Part #	Description	Weight	A	B	C	D
138 6551	Heel Shroud - Curved	26.9 lbs	6.88"	8.13"	5.88"	1.00"
138 6529	Heel Shroud - Straight	29.6 lbs	6.88"	8.13"	5.88"	1.00"
157 1027	Heel Shroud - Curved	59.3 lbs	9.81"	10.63"	7.88"	1.19"
157 1019	Heel Shroud	65.1 lbs	9.81"	10.63"	7.88"	1.19"
ES6697-2	Heel Shroud	45.9 lbs	7.49"	9.91"	6.00"	2.30"
ES6697-3	Heel Shroud	29.9 lbs	7.49"	7.00"	4.00"	1.24"
ES6697-4	Heel Shroud	22.4 lbs	7.49"	7.00"	4.00"	1.24"
ES6697-5	Heel Shroud	87.5 lbs	9.99"	12.00"	8.00"	2.00"
ES6697-7	Heel Shroud	189.5 lbs	9.84"	13.70"	9.88"	3.94"



### Corner Guard Protectors

Part #	Description	Weight	Model	A	B
253 0060/61	Bolt On Corner Protector - RH/LH	20.5 lbs	916-953	8.31"	12.25"
253 0062/63	Bolt On Corner Protector - RH/LH	28.2 lbs	916-963	8.19"	13.38"
173 5426/27	Bolt On Corner Protector - RH/LH	30.2 lbs	960-977	8.75"	13.0"
253 0064/65	Bolt On Corner Protector - RH/LH	38.6 lbs	960-977	8.94"	15.00"
173 5428/29	Bolt On Corner Protector - RH/LH	35.8 lbs	980-988	9.25"	14.5"
253 0066/67	Bolt On Corner Protector - RH/LH	70.1 lbs	980-988	10.98"	17.50"



### Weld On Lip Shrouds

Part #	Description	Weight	A	B	C	D	E
10WS	Weld On Lip Shroud	19.6 lbs	10.00"	7.00"	7.38"	1.50"	30°
13WS	Weld On Lip Shroud	40.7 lbs	13.00"	10.00"	10.25"	1.75"	23°
WS25	Weld On Lip Shroud	4.0 lbs	2.50"	2.50"	4.88"	1.75"	22°
WS45	Weld On Lip Shroud	14.2 lbs	4.50"	4.50"	7.17"	2.09"	30°
WS80	Weld On Lip Shroud	33.4 lbs	8.00"	7.00"	8.57"	2.79"	30°
4ML50UC	Weld On Lip Shroud	14.6 lbs	5.59"	5.15"	8.12"	1.38"	30°
4ML70UC	Weld On Lip Shroud	45.3 lbs	9.47"	8.93"	9.49"	2.38"	30°



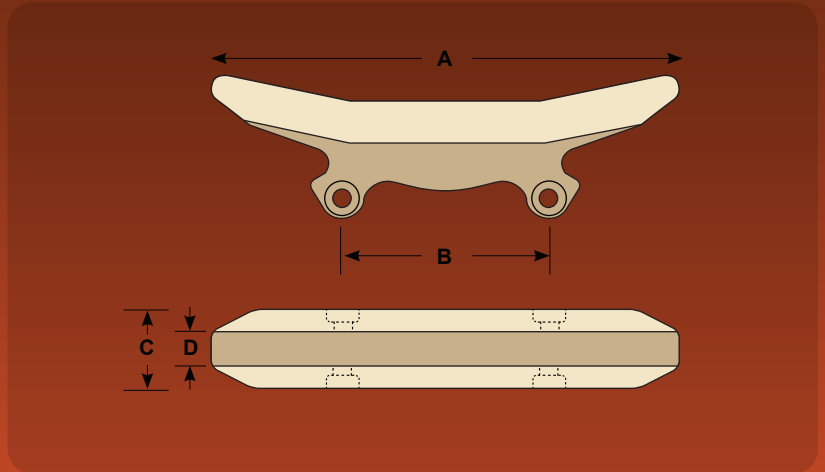

### Black Cat Sidebar Protectors for Caterpillar® Applications

Part #	Description	Pin	Retainer	Model	Weight	A	B	C	D
135 8246	Sidebar Protector	135 9242	114 0359	962G,H, 972G,H, 980G,H	24.0 lbs	18.19"	9.38"	2.69"	1.13"
112 2489	Sidebar Protector	112 2490	132 0999	New B, C, D, S Excavator Buckets	40.0 lbs	17.13"	7.94"	2.88"	1.38"
166 2877	Sidebar Protector	132 0998	132 0999	New E, F, G, H, V Excavator Buckets	40.5 lbs	18.13"	7.88"	3.00"	1.56"
9J9600	Sidebar Protector	135 9350	114 0359	980, 988, D8, D9	44.5 lbs	22.69"	10.00"	3.63"	1.50"
152 0027	Adapter Plate for 9J9600	N/A	N/A	D8, D9	18.3 lbs	16.06"	10.00"	1.19"	N/A
1U0740	Sidebar Protector	1U0739	8E5559	990, 992, 300 Series, 5080	55.6 lbs	23.81"	11.50"	4.13"	2.13"
1U0740HD	Sidebar Protector	1U0739	8E5559	992C, D, G, 990	67.2 lbs	23.81"	11.50"	4.13"	2.13"
112 2494	Sidebar Protector	132 0998	132 0999	New E, F, G, H Excavator Buckets	77.3 lbs	37.00"	20.56"	3.13"	1.63"
125 0800	Sidebar Protector	8E4708	4T4707	994, D10, D11, 5080	121.6 lbs	40.00"	23.63"	5.25"	2.75"

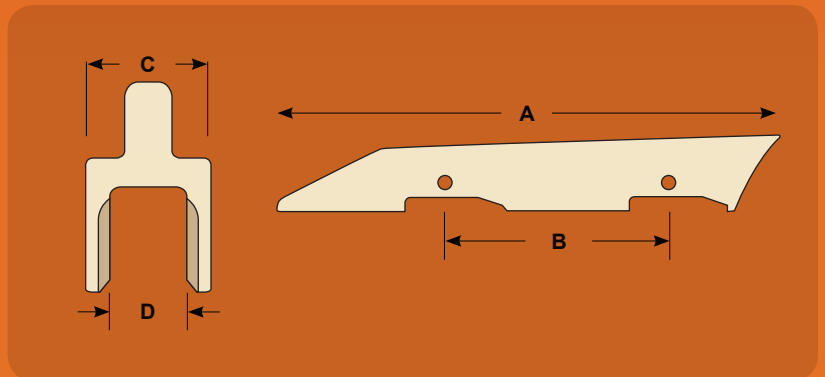

### Universal Sidebar Protectors

Part #	Description	Pin	Retainer	Model	Weight	A	B	C	D
VS450	Vertical Shroud	VSP2-SL	VSR3-SL	Universal	43.7 lbs	30.34"	13.5"	2.63"	N/A
VS450EXT	Vertical Shroud Extension	VSP2-SL	VSR3-SL	Universal	27.3 lbs	21.04"	N/A		
VS500	Vertical Shroud	VSP3-SL	VSR3-SL	Universal	67.5 lbs	32.88"	16.0"	3.44"	N/A
VS550	Vertical Shroud	VSP3-SL	VSR3-SL	Universal	86.6 lbs	35.75"	17.13"	4.0"	N/A
VSMWN	Vertical Shroud Mount	N/A	N/A	Universal	4.7 lbs			N/A	N/A
VSM100WN	Vertical Shroud Mount	N/A	N/A	Universal	11.4 lbs			2.75"	1.06"
VSM150WN	Vertical Shroud Mount	N/A	N/A	Universal	12.9 lbs			3.44"	1.56"
VSM175WN	Vertical Shroud Mount	N/A	N/A	Universal	12.1 lbs			3.44"	1.84"
VSM200WN	Vertical Shroud Mount	N/A	N/A	Universal	11.1 lbs			3.44"	2.06"
VSM250WN	Vertical Shroud Mount	N/A	N/A	Universal	13.2 lbs			3.94"	2.56"



Modulok Center

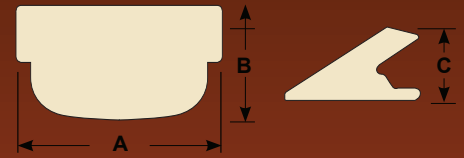

Adapter Cover

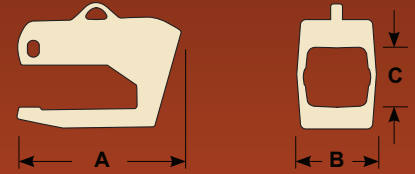

### Modulok Replacement Parts

Part #	Description	Model	Notes	Pin	Retainer	Weight	A	B	C	
232 0152	K150 Adapter Cover 990/992	K Series	Use with 232 0158	232 0157	114 0359	97.8 lbs	15.86"	8.00"	5.27"	
232 0153	K150 Adapter Cover 990/992	992G/992K	Use with 232 0159	232 0157	114 0359	88.9 lbs	16.03"	8.20"	4.98"	
119 9604	J600 Center Adapter	J Series 992G/992K								
119 9605	J600 Corner Adapter									
167 0033	Adapter Cover 992G/992K Center		Use with 119 9604	113 9608	113 9609	78.2 lbs	0	7.43"	10.10"	
167 0034	Adapter Cover 992G/992K Ends		Use with 119 9605	113 9608	113 9609	75.8 lbs	0	7.23"	10.30"	
275 5460/61/62	Half arrow segments	J/K Series 992G/992K	Bolt on between teeth							
208 5327/28/29	Top cover plates									
251 2180	K130 Adapter Cover 988/990	K Series 988K/990K	Use with 232 0138	251 6730	114 0359	60.6 lbs	13.75"	5.44"	4.72"	
251 2461	K130 Adapter Cover 988/990		Use with 232 0139	251 6730	114 0359	59.3 lbs	13.75"	5.44"	4.70"	
109 9080/81/82	Half Arrow segments		Bolt on between teeth							
257 1778/79/80	Top cover plates									
186 3294	J550 Adapter	J Series 992C/992D				112.2 lbs	26.07"	4.74"	6.85"	
8E9543	Adapter Cover 992C/992D		Use with 186 3294	107 3378	107 8559	47.2 lbs	13.49"	8.40"	8.90"	
8E9514	Edge Cover 992C/992D Center		Integrated Locking Tab			N/A	90.6 lbs	18.45"	8.35"	4.55"
8E9515/16	Edge Cover 992C/992D RH/LH						N/A	69.9 lbs	18.43"	8.37"

### Bolt On Wear Plates

Part #	Model	Weight	Length	Height	Width	Bolt Size
9W6747	944, 950, 960, 962	42.2 lbs	20.75"	10.00"	1.00"	0.75"
9W6748	963	41.8 lbs	21.13"	10.00"	1.00"	0.75"
9W6749	966D, E, F, 970, 973	69.8 lbs	22.25"	10.00"	1.38"	0.75"
161 8573	966G, H, 972G, H	66.6 lbs	22.25"	10.00"	1.38"	0.75"
7V0910	973, 980C	96.2 lbs	23.63"	11.50"	1.63"	0.75"
9W6750	973, 980C, F	69.8 lbs	23.50"	10.00"	1.38"	0.75"
109 9215	980G, H	72.0 lbs	24.50"	10.00"	1.38"	0.75"
6Y3609	988B, F	75.8 lbs	26.75"	10.00"	1.38"	1.00"
9V5793	988B, F	55.1 lbs	26.75"	10.00"	1.38"	1.00"
6Y3573	990	128.0 lbs	32.00"	13.00"	1.38"	1.00"
6W0276	992C, D	122.0 lbs	38.63"	13.00"	1.38"	1.00"
6Y3610	992C, D	182.0 lbs	38.63"	13.00"	1.75"	1.00"
100 4015	994, D	512.0 lbs	47.00"	14.75"	3.00"	1.25"



## Black Cat Bucket Protection

Distributed By:



Caterpillar® and other identities and/or trademarks referred to in this publication are the registered marks of the entities noted herein. The use of any trademarks of others than Black Cat Blades Ltd. are solely and exclusively for identification, informational, comparative, and descriptive purposes. Black Cat Blades Ltd. is not affiliated with any owner of such registered marks and does not make, use, or sell any products manufactured by any such entity identified in this publication.